

# Remote5104V

## AIRBORNE PARTICLE COUNTERS



**C**ompatible with VHP, the Remote 5104V meets the stringent requirements of today's aseptic processing application. In addition, the Remote 5104V was designed to operate in CLASS 1 DIV 2 hazardous environments found in many challenging applications.

The Remote 5104V uses a critical orifice and external vacuum source for flow control. Built-in flow monitoring assures accuracy and reliability of the sensor's performance.

With a sensitivity of 0.5  $\mu\text{m}$  and 1.0 CFM flow rate, the Remote 5104V provides real-time continuous data collection at a cost-effective price per point and integrates seamlessly with facility monitoring and building management systems.

### F E A T U R E S

- Class I Division 2 Rating
- 0.5- 5.0  $\mu\text{m}$  (optional channels up to 25  $\mu\text{m}$ )
- 1.0 CFM (28.3 LPM) flow rate
- Up to 4 channels of simultaneous count data
- Real-time continuous monitoring
- 316L stainless steel, wash down splash tight enclosure
- Status indicators for power, flow, service, sampling
- RS-485 Modbus communication
- Interfaces to facility monitoring systems
- Uses external vacuum source
- 2 year warranty



 Learn More

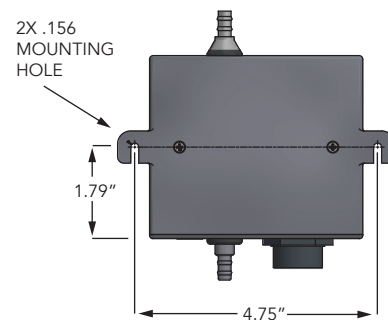
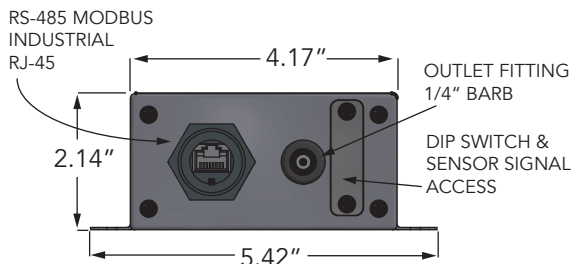
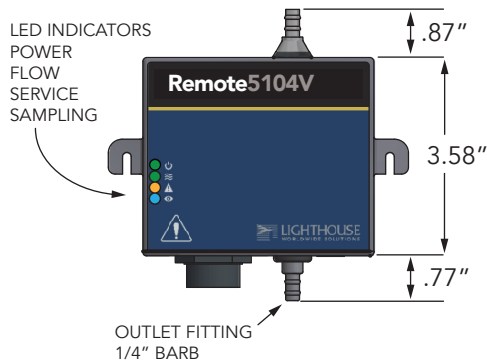

## TECHNICAL DATASHEET

### Remote5104V Remote Airborne Particle Counters

#### Features

<b>Size Range</b>	0.5 - 25.0 $\mu$ m
<b>Standard 2 Channels</b>	0.5, 5.0 $\mu$ m; (0.5, 1.0, 5.0, 25.0 $\mu$ m)
<b>Flow Rate</b>	1.0 CFM (2.83 LPM)
<b>Laser Source</b>	Laser Diode
<b>Zero Count Level</b>	< 1 Count / 5 minutes (meets specifications of JIS B 9921 and reporting requirements of ISO 21501-4 Annex C)
<b>Concentration Limits</b>	1,000,000 Particles/ft <sup>3</sup> @10% Coincidence loss suitable for ISO classes 1-8 cleanrooms
<b>Data Storage</b>	2,300
<b>Calibration</b>	ISO 21501-4 Compliant and Accredited ISO 17025
<b>External Vacuum Requirements</b>	18" (45.72 cm) of Hg
<b>Air Flow</b>	Internally monitored
<b>Communication Modes</b>	Serial - 485 Modbus RJ45
<b>LED Indicators</b>	Power, flow, service, sampling
<b>Connector</b>	Industrial RJ-45
<b>Enclosure</b>	316L Stainless steel, wash down resistant, splash tight
<b>Power</b>	24 VDC
<b>Dimensions</b>	5.42" (l) x 2.14" (w) x 3.58" (h), [13.76 cm (l) x 5.43 cm (w) x 9.09 cm (h)]
<b>Weight</b>	15.6 oz (0.44 kg)
<b>Software</b>	LMS Express, LMS Pharma, LMS Pro and LMS Xchange
<b>Includes</b>	24 VDC power adapter and power cord, Calibration Certificate

**Optional** Temperature & humidity probe, 1 CFM isokinetic sample probe, Beveline tubing, printed operators manual, Purge Filter

Distributed By:



Lighthouse Worldwide Solutions reserves the right to change specifications without notice.

www.golighthouse.com  
info@golighthouse.com

+1-800-945-5905  
+1-541-770-5905

